

Series 1896M

Pressure Relief Valves for Air,
Steam, Vapor & Liquid Service

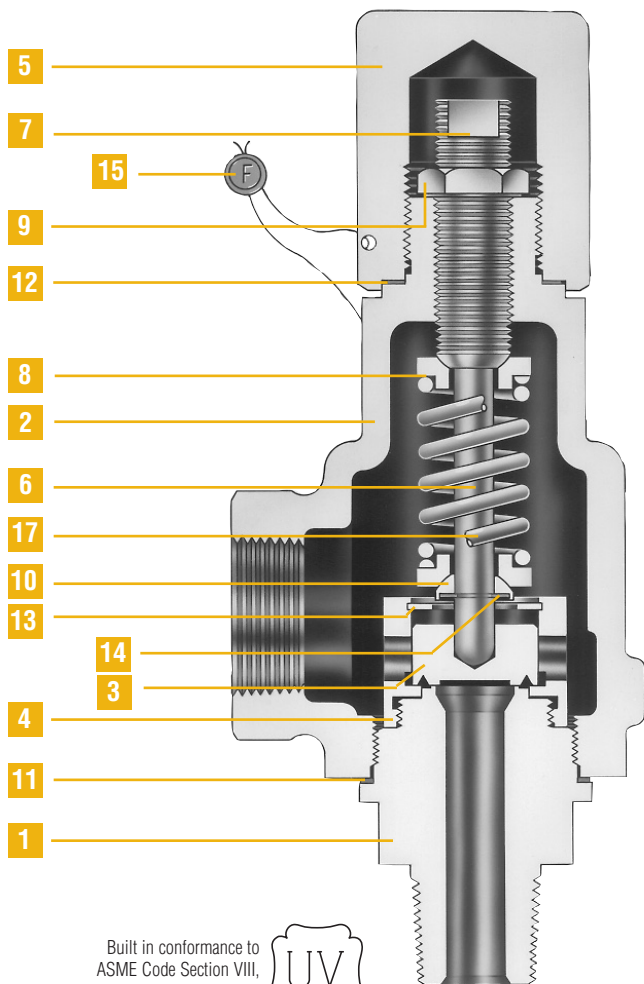

- Built in conformance to ASME Code Section VIII for Air, Steam, and Liquid Service.
- Set pressures to 300 psig.
- Brass body and trim.
- Bronze bonnet and cap.



Built in conformance to ASME Code Section VIII, Capacity Certified by National Board



Bill of Materials

Item No.	Part Name	Material
1	Body	ASTM B16 H.H. Brass
2	Bonnet	SB-62 Bronze
3	Disc	ASTM B16 H.H. Brass
4	Guide	Brass
5	Cap, Plain Screwed	Brass
6	Stem	St. St.
7	Spring Adj. Screw	Brass
8	Spring Button	St. St.
9	Jam Nut	Brass
10	Stem Shoulder	St. St.
11	Body Gasket	316 St. St.
12	Cap Gasket	316 St. St.
13	Lift Stop Ring	St. St.
14	Retaining Ring- Stem Shoulder	St. St.
15	Wire Seal	Stainless Steel Wire/Lead Seal
16	Nameplate (not shown)	St. St.
17	Spring	316 St. St.

Selection Table

(Connections: MNPT x FNPT)

Type Number	Service	Valve Size Inlet x Outlet	Maximum Set Pressure		Maximum Back Pressure		Materials	
			psig	barg	psig	barg	Body / Bonnet	Spring
			-400°F to +400°F	-240°C to +204°C	100°F	37.8°C		
1896M2-M20	Air, Steam & Vapor	1/2 x 3/4	300	20.7	50	3.45	Brass / Bronze	316 St. St.
1896M3-M20		3/4 x 3/4						
1896ML2-M20	Liquid	1/2 x 3/4	300	20.7	50	3.45	Brass / Bronze	316 St. St.
1896ML3-M20		3/4 x 3/4						

General Notes:

1. Type numbers shown designate valves with plain screwed caps. Test lever required for air, steam or hot water service (above 140°F / 60°C). For packed lever change the three digit type number suffix from "-M20" to "-M40". Example: 1896M2-M20 becomes 1896M2-M40.

Capacity Tables: ASME PRESSURE VESSEL CODE (UV)

AIR 10% OVERPRESSURE Capacities in Standard Cubic Feet Per Minute at 60° F	
Set Pressure (psig)	Air Capacity
15	51
20	59
30	74
40	92
50	109
60	126
70	144
80	161
90	178
100	195
120	230
140	264
160	299
180	334
200	368
220	403
240	437
260	472
280	506
300	541

STEAM 10% OVERPRESSURE Capacities in Lbs. Per Hour at Saturation Temperature	
Set Pressure (psig)	Steam Capacity
15	144
20	166
30	210
40	258
50	307
60	356
70	404
80	453
90	501
100	550
120	647
140	744
160	841
180	938
200	1035
220	1132
240	1229

WATER 10% OVERPRESSURE Capacities in U.S. Gallons Per Minute at 70° F (See Note 2)	
Set Pressure (psig)	Water Capacity
15	9.3
20	10.6
30	12.7
40	14.6
50	16.3
60	17.9
70	19.4
80	20.7
90	22.0
100	23.1
120	25.4
140	27.4
160	29.3
180	31.1
200	32.7
220	34.3
240	35.9
260	37.3
280	38.8
300	40.1

- Notes:**
1. Capacities at 30 PSIG and below are based on 3 PSI overpressure.
 2. To determine water capacity at 25% overpressure, multiply the capacity at 10% by 1.066.
 3. Maximum set pressure for steam service is 240 psig (saturation temperature of 400°F)

Actual Orifice Areas				
Inlet Size	Air, Gas & Steam		Liquids	
	Sq. In.	Sq. mm	Sq. In.	Sq. mm
1/2" or 3/4"	0.110	71	0.110	71

- Notes:**
1. For sizing purposes, the coefficient of discharge K_d is 0.779 for air, gas, steam and vapor.
 2. For liquid service, use the ASME liquid equation with a coefficient of discharge K_d equal to 0.529.

Dimensions & Weights						
Type Number	A		B	C	Approx. Weight Lbs/Kgs	
	Plain Cap	Packed Lever				
1896M	In.	6 5/16	7 1/2	1 9/16	2 7/16	3
	mm	160	190	40	62	1.4

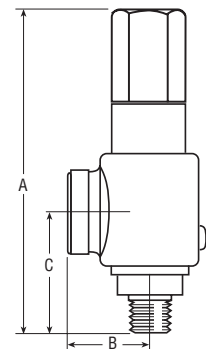

Farris Engineering Division of Curtiss-Wright Flow Control Corporation

10195 Brecksville Road, Brecksville, OH 44141 USA • Telephone: 440-838-7690 • Fax: 440-838-7699 • www.farrisengineering.com

Facilities: Brecksville, OH USA; Brantford, Ontario; Edmonton, Alberta, Canada; Kettering, Northants, UK; Delhi, India; Tianjin, China

Offices: worldwide. For a listing of our global sales network, visit our website at www.farrisengineering.com.

While this information is presented in good faith and believed to be accurate, Farris Engineering, Division of Curtiss-Wright Flow Control Corporation, does not guarantee satisfactory results from reliance on such information. Nothing contained herein is to be construed as a warranty or guarantee, expressed or implied, regarding the performance, merchantability, fitness or any other matter with respect to the products, nor as a recommendation to use any product or process in conflict with any patent. Farris Engineering, Division of Curtiss-Wright Flow Control Corporation, reserves the right, without notice, to alter or improve the designs or specifications of the products described herein.