

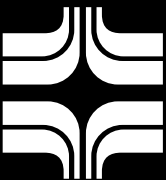

# Nuclear Products



**Farris Engineering**

*Division of Curtiss-Wright Flow Control*



ISO 9001 : 2000
Registered Company
TUV Rheinland of North America, Inc.



# Nuclear Products Division



## Engineering Support

- Dedicated Engineering Support Group
- Assistance with Valve Sizing and Selection
- Design Report Preparation
- Seismic Analysis and Testing
- Development of New Valve Designs

## Manufacturing

- Replacement Valve Parts
- Complete Manufacture and Test Program for Pressure Relief Valves built in conformance with ASME Section III, Division 1 Code for Class 1, 2 or 3 Components

- NCA-4000
- NQA-1
- 10CFR Part 50 Appendix B
- N285.0
- CSA Z299.2

## National Board & ASME Accepted Test Lab

- Air
- Water

## ASME NV, UV, V, VR Stamps

## Quality Programs

# Pressure Relief Valves

## Series 2600

ASME Section VIII and III NB Certified: air, steam & water  
European CE Approved

Sizes 1" X 2" to 20" X 24". Effective orifice areas from 0.110 to 159 square inches. Pressures from 15 to 6000 psig. Temperature range from -450° F to +1500° F. Steel body and bonnet with stainless steel trim.

Optional balanced bellows design isolates working parts and top-works from fouling or corrosive service, and nullifies the effects of back pressure on valve performance.

The "D" to "T" orifices meet API Standard 526 covering orifice areas and center-to-face dimensions. Super capacity types range from "U" (31.5 sq. in.) to "Z" (176.7 sq. in.) actual areas and have a maximum set pressure limit of 300 psig.

Optional materials of construction include complete 316 stainless steel, Monel®, and Hastelloy® C. Higher temperature models use chrome moly body and bonnet.

Optional O-ring elastomer seat available for maximum tightness.

Applications: air, steam, gas, vapor, and liquid applications.

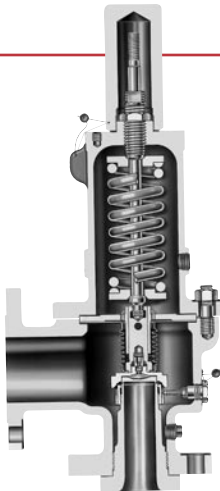

## Series 2700

ASME Section VIII and III NB Certified: air, steam & water  
European CE Approved

Sizes 1/2" X 1" to 1-1/2" X 2-1/2". Actual orifice areas from 0.068 to 0.573 square inches. Pressures from 15 to 6500 psig. Temperature range of -450° F to +750° F.

Stainless steel body and trim with carbon steel bonnet. Optional materials of construction include complete 316 stainless steel, Monel®, and Hastelloy® C. Materials suitable for NACE service available.

Available with threaded, flanged, socket weld, welding nipple or sanitary connections. Optional O-ring seat for ultimate tightness. Maximum blow down of 10% to 20% on all fluids. Balanced design available in "C" and "D" orifices which nullify effects of back pressure.

Applications: air, steam, gas, vapor, and liquid applications.

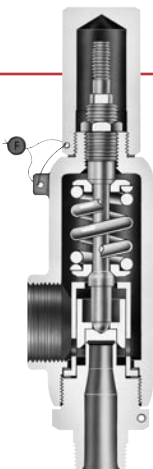

# Pressure Relief Valves



## Series 3800

ASME Section VIII and III NB Certified: air & water  
European CE Approved

Sizes 1" X 2" to 12" X 16". Orifice areas from 0.110 to 109 square inches. Pressures from 20 to 6170 psig. Temperature range of -450° F to +500° F. Steel body and bonnet with stainless steel trim. Semi-nozzle design.

The "D" to "T" orifices meet API Standard 526 covering orifice areas and center-to-face dimensions. Full bore designs available with 1" through 12" inlets and orifice areas from 0.719 to 109 square inches giving maximum capacity for a given inlet size. All stainless steel snap acting and modulating non-flowing pilot controls minimize product loss and provide maximum resistance to corrosion.

Standard O-ring elastomer seat main valve and pilot control minimizes fugitive emissions and allows operation within 95% of set pressure. Materials include Viton®, Buna N, ethylene propylene, silicone and Teflon®. Optional materials of construction include complete 316 stainless steel.

Applications: air, gas, vapor, and liquid applications where maximum seat tightness, operating pressures and precise adjustment are required. Excellent for natural gas pipeline and compressor applications.

*Monel is a registered trademark of Inco Alloys International Inc.  
Hastelloy and Hastelloy C are registered trademarks of Haynes International Inc.*

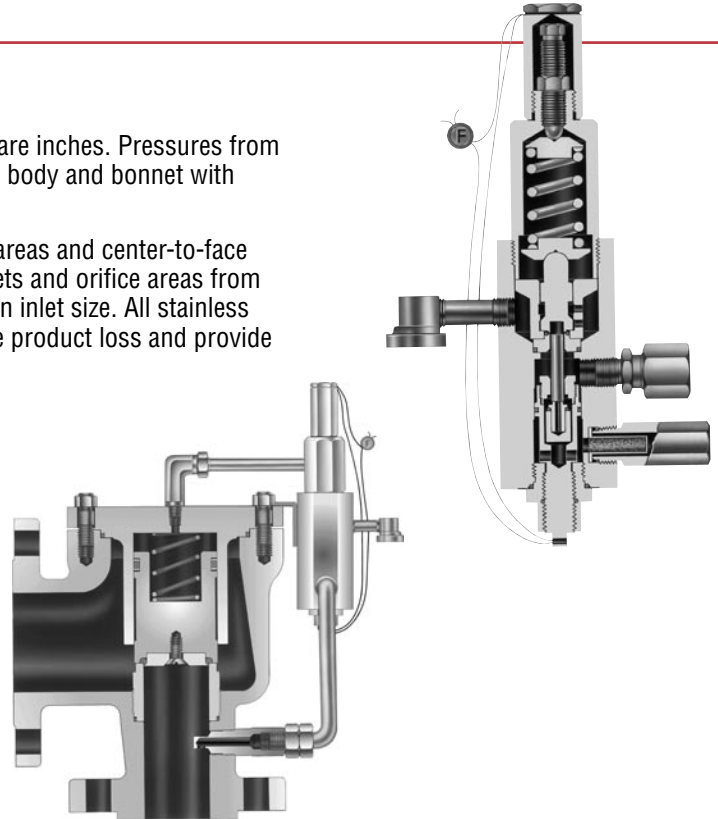

## Series 4700

ASME Section VIII and III NB Certified: water, air and steam

Sizes 1/2" X 3/4" to 3/4" X 1" & 1" x 1". Effective orifice areas from 0.028 to 0.225 square inches. Pressures from 15 to 2300 psig. Temperature range from -450° F to +1000° F. Steel body and bonnet with stainless steel trim as standard. Full nozzle construction.

Design features compact bolted inlet flange construction to minimize installation height. Optional balanced bellows isolates working parts and top works from fouling or corrosive service and nullifies the effects of back pressure on valve performance.

Optional materials of construction include complete 316 St. St., Monel®, and Hastelloy® C. Also available in materials in compliance with NACE Standards.

Applications: air, steam, gas, vapor, and fluid process applications for use with variable back pressure.

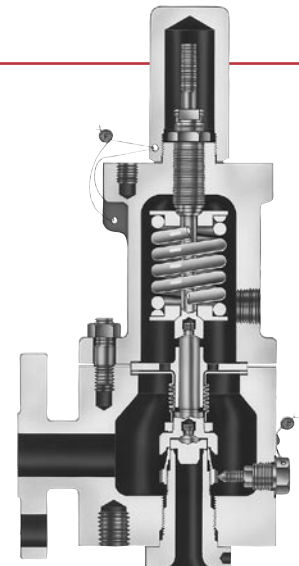

*Viton is a registered trademark of DuPont Dow Elastomers.  
Teflon is a registered trademark of the DuPont Company.*

## SizeMaster™ Mark IV Pressure Relief Valve Engineering Software • Version 4.3

### Easier Sizing and Selection!

All sizing equations and selection algorithms are based on ASME Code requirements, API standards and best engineering practice as determined by Farris Engineering.

#### New Features:

- Quick Size Database
  - Allows the user to set up a database in 2 short steps
  - User can now begin a quick size application with one click of the mouse
- New Tube Rupture scenario added
- New Metric Dimensional Drawings
- New Max/Min “Revision Control” Mechanism
  - “Minimum control” reduces database size
- Worksheet Diagnostic Report expanded to include all warnings that SMP generates
- Critical vs Sub-Critical Flow Calculations: Gas or Vapor
  - SMP automatically checks and compensates for sub-critical flow calculations on conventional and/or pilot operated valves
- All model selection (2600 Series) default to select new API sizes
- “Quote” Tab renamed to “Export”
- SMP Desktop “Database Connect” Label displays name of “connected database”
- Model Number Selection: Provides better descriptions on æSpecial Materials”

SizeMaster Mark IV pressure relief valve engineering software is available online at [www.cwfc.com](http://www.cwfc.com) or directly from Farris Engineering.

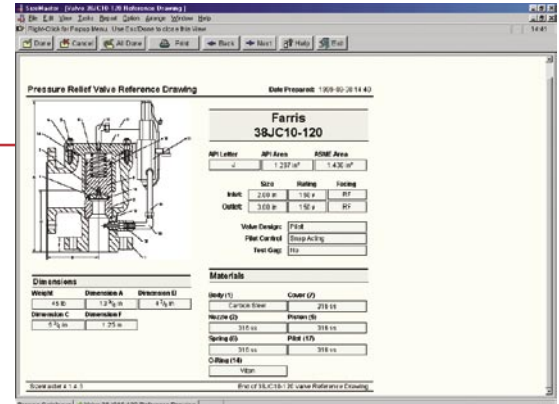

Interactive catalog



## Farris Engineering

Division of Curtiss-Wright Flow Control Corporation

10195 Brecksville Road, Brecksville, OH 44141 USA • Telephone: 440/838-7690 • Fax: 440/838-7699 • [www.cwfc.com](http://www.cwfc.com)

**Nuclear Product Division:** 15 Shaver St., Brantford, ON CANADA N3T 5T3 • Telephone: 519/756-4800 • Fax: 519/756-8749

**Facilities:** Brecksville, OH USA; Brantford Ontario CANADA; Bridport UK

**Offices:** worldwide. For a listing of our global sales network, visit our website at [www.cwfc.com](http://www.cwfc.com).

While this information is presented in good faith and believed to be accurate, Farris Engineering, Division of Curtiss-Wright Flow Control Corporation, does not guarantee satisfactory results from reliance on such information. Nothing contained herein is to be construed as a warranty or guarantee, expressed or implied, regarding the performance, merchantability, fitness or any other matter with respect to the products, nor as a recommendation to use any product or process in conflict with any patent. Farris Engineering, Division of Curtiss-Wright Flow Control Corporation, reserves the right, without notice, to alter or improve the designs or specifications of the products described herein.