



# The First Line of Safety



**CURTISS  
WRIGHT**  
Flow Control Corporation



# Process Pressure Relief Valves

## Series 2600

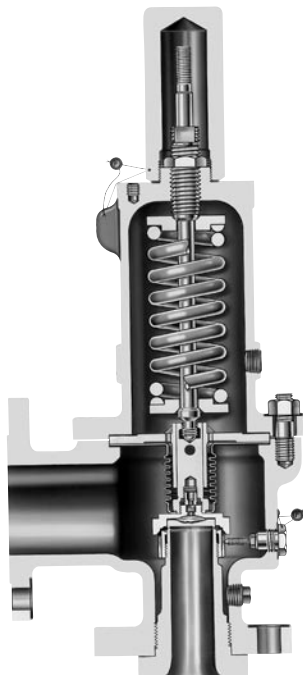

ASME NB Certified: Air, Steam & Water  
European CE Approved

Sizes 1" X 2" to 20" X 24". Actual orifice areas from 0.150 to 176.7 square inches. Pressures from 15 to 6000 psig. Temperature range from -450° F to +1500° F. Steel body and bonnet with stainless steel trim.

Optional balanced bellows design isolates working parts and top-works from fouling or corrosive service, and nullifies the effects of back pressure on valve performance.

The "D" to "T" orifices meet API Standard 526 covering orifice areas and center-to-face dimensions. Super capacity types range from "W" (63.62 sq. in.) to "Z" (176.7 sq. in.) and have a maximum set pressure limit of 300 psig.

Optional materials of construction include complete 316 stainless steel, Monel®, and Hastelloy® C. Also available with materials in compliance with NACE standards. Higher temperature models use chrome moly body and bonnet.

Optional O-ring elastomer seat available for maximum tightness.

Applications: air, steam, gas, vapor, and liquid process applications.

## Series 3800

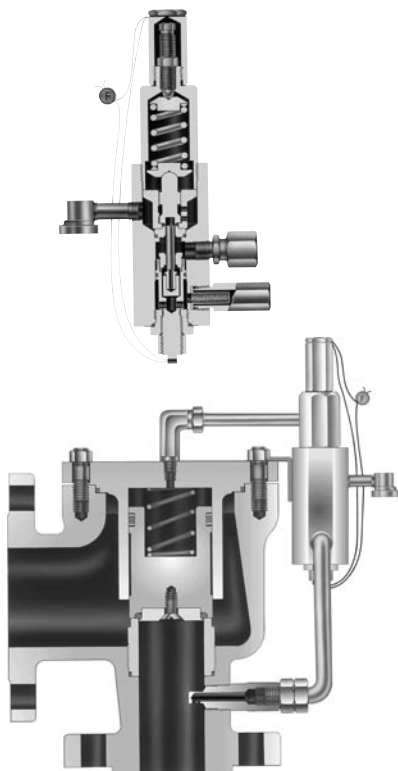

ASME NB Certified: Air, Steam & Water  
European CE Approved

Sizes 1" X 2" to 12" X 16". Actual orifice areas from 0.15 to 109 square inches. Pressures from 20 to 6170 psig. Temperature range of -450° F to +500° F. Steel body and bonnet with stainless steel trim. Semi-nozzle design.

The "D" to "T" orifices meet API Standard 526 covering orifice areas and center-to-face dimensions. Full bore designs available with 1" through 12" inlets and orifice areas from 0.719 to 109 square inches giving maximum capacity for a given inlet size. All stainless snap acting and modulating non-flowing pilot controls minimize product loss and provide maximum resistance to corrosion.

Standard O-ring elastomer seat main valve and pilot control minimizes fugitive emissions and allows operation within 95% of set pressure. Materials include Viton®, Buna N, ethylene propylene, silicone and Teflon®. Optional materials of construction include complete 316 stainless steel.

Applications: air, steam, gas, vapor, and liquid services where maximum seat tightness, operating pressures and precise adjustment are required. Excellent for natural gas pipeline and compressor service.

*Monel is a registered trademark of Inco Alloys International Inc.*

*Hastelloy and Hastelloy C are registered trademarks of Haynes International Inc.*

*Viton is a registered trademark of DuPont Dow Elastomers.*

*Teflon is a registered trademark of the DuPont Company.*

# Process Pressure Relief Valves



## Series 2850/2856

ASME NB Certified: Air & Steam

Sizes 3/4" X 1" to 1-1/2" X 2" (2850) and 3/4" X 1-1/4" to 2" X 3" (2856). Effective orifice areas from 0.098 to 1.048 square inches. Pressures from 15 to 300 psig. Temperature range of -20° F to +750° F (2850) and -450°F to +400°F (2856).

Materials of construction include stainless steel body and trim (2850) and bronze/brass body and trim with bronze bonnet (2856).

Applications: air, steam, gas, vapor and non-Code liquid applications where service is compatible with stainless steel (2850) or brass and bronze (2856). Also suitable for cryogenic applications.

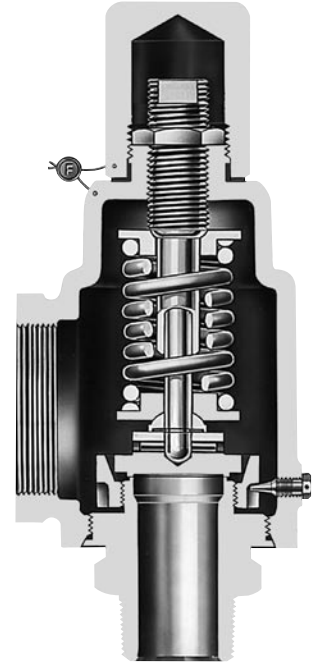

## Series 1890/1896M

ASME NB Certified: Air, Steam & Water

Sizes 1/2" X 1" & 3/4" X 1" (1890) and 1/2" X 3/4" & 3/4" X 3/4" (1896M). Effective orifice areas of 0.077 (liquid) and 0.089 (vapor) square inches. Pressures from 15 to 800 psig for stainless steel (1890) and 15 to 300 psig for bronze (1896M). Temperature range from -20° F to +750° F (1890) and -450°F to +400°F (1896M).

Materials of construction include stainless steel body and trim (1890) and brass body and trim with bronze bonnet (1896M).

Applications: air, steam, gas, vapor and liquid process applications (1890) and where service is compatible with brass and bronze (1896M). Also suitable for cryogenic applications.

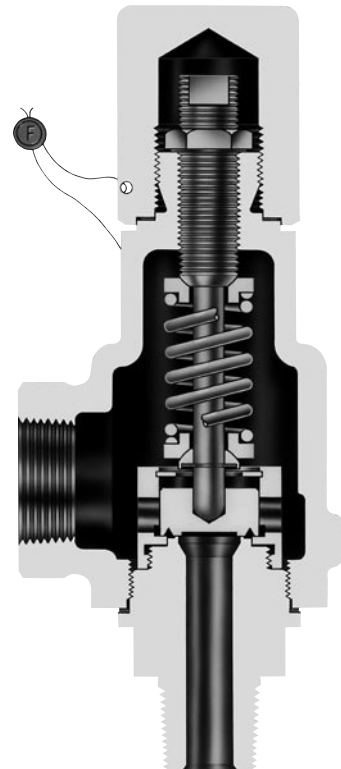

## Series 6400/6600

ASME NB Certified: Steam & Air

Sizes 1" X 2" to 4" X 6". Actual orifice areas from 0.150 to 7.087 square inches. Pressures from 15 to 1500 psig. Temperature range from -20° F to +1000° F. Steel body and bonnet with stainless steel trim.

Double blow down ring design meets the requirements of Section I of ASME Code. Temperature equalizing disc for maximum seat tightness. Available with exposed spring (6400) or closed bonnet (6600). Full nozzle design for ease of maintenance.

Applications: steam boilers (6400) and organic fluid vaporizers or hot water boilers (6600).

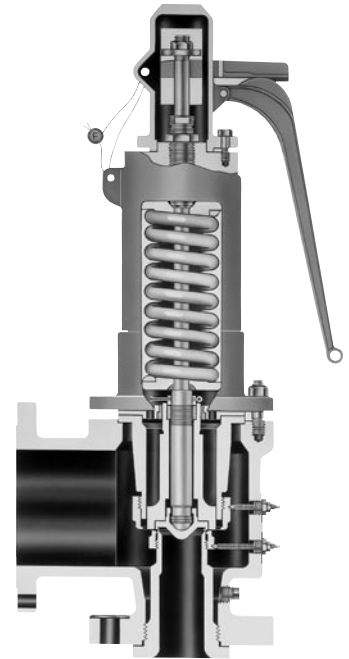

## Series 2600S

ASME NB Certified: Steam & Air  
European CE Approved

Sizes 1" X 2" to 20" X 24". Actual orifice areas from 0.150 to 176.7 square inches. Pressures from 15 to 6000 psig. Temperature range of -20° F to +1500° F. Steel body and yoke with stainless steel trim.

This enhanced version of Series 2600 offers an exposed spring and precipitation hardened stainless steel stem retainer for improved performance in steam applications. Also suitable for air and gases.

Supplied as standard with an open lifting lever to meet the requirements of Section VIII of ASME Code. Most standard 2600 Series options, including O-ring seats and balanced bellows available upon request.

Applications: steam, air and gases. Suitable for use on steam turbines and reducing stations.

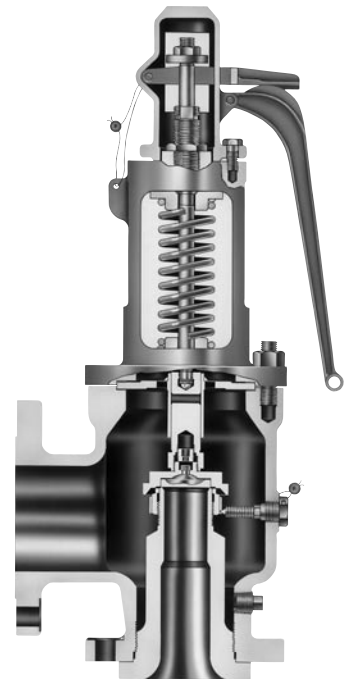



# Process Pressure Relief Valves

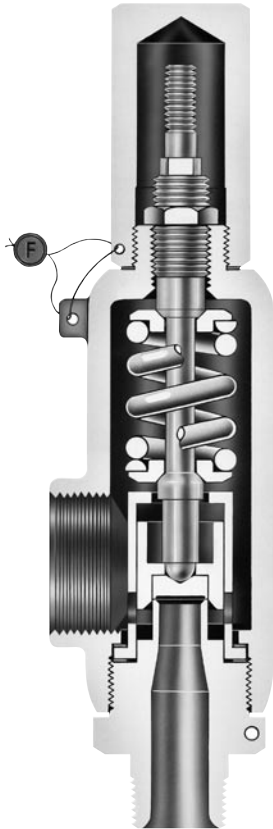

## Series 2700

ASME NB Certified: Air, Steam & Water  
European CE Approved

Sizes 1/2" X 1" to 1-1/2" X 2-1/2". Effective orifice areas from 0.068 to 0.573 square inches. Pressures from 15 to 6500 psig. Temperature range of -450° F to +750° F.

Stainless steel body and trim with carbon steel bonnet. Optional materials of construction include complete 316 stainless steel, Monel, and Hastelloy C. Materials suitable for NACE service available.

Available with threaded, flanged, socket weld, welding nipple or sanitary connections. Optional O-ring seat for ultimate tightness. Maximum blow down of 10% to 20% on all fluids. Balanced design available in "C" and "D" orifices which nullify effects of backpressure.

Applications: air, gas, vapor, and liquid process service.



*Series T6000*



*Series T1500*

## Universal Test Stands

The Farris T6000 Series Universal Test Stand is a fully self-contained unit capable of handling air and water testing to 6000 psig. It tests valves with 1" to 8" raised face inlet flanges and threaded valves with 1/2" to 2" MNPT and FNPT connections. This single test station accommodates all valve sizes.

Other features include corrosion resistant stainless steel test drum and table; digital test gauge for accuracy and easy operation; and a three-stage, air-cooled compressor rated to 3000 psig. The unit's test drum and accumulator are built to and tested per the ASME Code. Each accommodates a volume of 1.5 cubic feet to provide sufficient capacity to cushion the valves during set pressure testing.

In addition to Series T6000, there are Farris Universal Test Stands rated for 1500 psig and 2500 psig.

## SizeMaster™ Mark IV Pressure Relief Valve Engineering Software Version 4.3

Now you can accurately size and select a pressure relief valve for any combination of process applications with SizeMaster™ Mark IV pressure relief valve engineering software version 4.3. This program for Windows® (all versions) brings unprecedented integration of standard engineering practice to the task of sizing and selecting pressure relief valves.

With SizeMaster Mark IV software, you can define as few as one or as many as 64 different sizing scenarios including blocked flow, fire, thermal and tube rupture, from a scenario matrix grid. Selection of the pressure relief valve is automatically based on the relief area of the worst case scenario. Various Wizards make the most complicated task simple; for instance, the Capacity Wizard allows you to determine accurate vapor generation for vessels of all types.

### SizeMaster Features:

- Quicksize Database
- Tube Rupture Scenario
- Metric dimensional drawings
- Omega 2-phase sizing (D.I.E.R.S.)
- Noise and reaction force calculators
- Multiple valve sizing
- Standard Windows user interface functions
- Support of network database access
- Database administration tools
- Interactive product catalog
- Internal client/project database
- Complete revision control with definable database access
- English/Metric units definable by job level
- Import/export capabilities
- All reports in html format
- Online help including a variety of tutorials

SizeMaster Mark IV pressure relief valve engineering software is available online at [www.cwfc.com](http://www.cwfc.com) or directly from Farris Engineering.

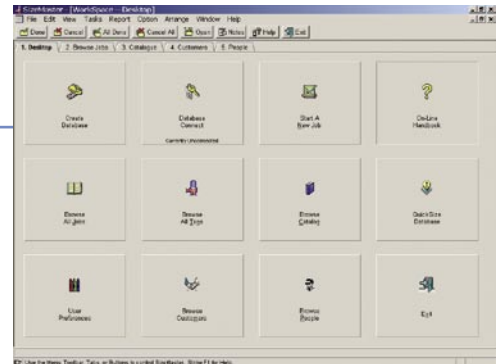

SizeMaster workspace

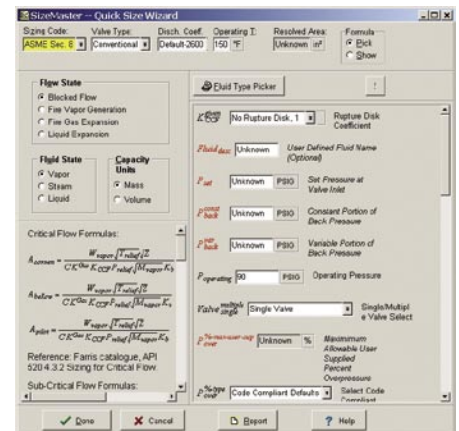

Quick Size Wizard

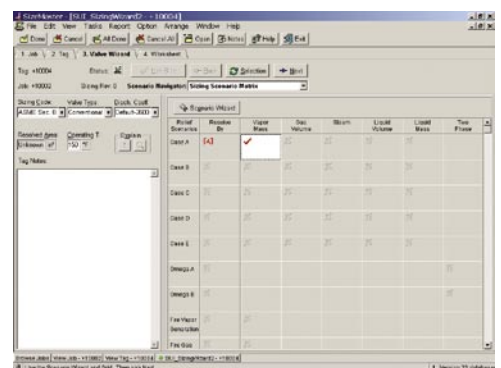

Sizing scenario matrix

# Farris Engineering

10195 Brecksville Road, Brecksville, OH 44141 USA • Telephone: 440-838-7690 • Fax: 440-838-7699 • [www.farrisengineering.com](http://www.farrisengineering.com)

**Facilities:** Brecksville, OH USA, E. Farmingdale NY USA, Brantford Ontario Canada, Bridport UK

**Offices:** worldwide. For a listing of our global sales network, visit our website at [www.farrisengineering.com](http://www.farrisengineering.com).

While this information is presented in good faith and believed to be accurate, Farris Engineering, Division of Curtiss-Wright Flow Control Corporation, does not guarantee satisfactory results from reliance on such information. Nothing contained herein is to be construed as a warranty or guarantee, expressed or implied, regarding the performance, merchantability, fitness or any other matter with respect to the products, nor as a recommendation to use any product or process in conflict with any patent. Farris Engineering, Division of Curtiss-Wright Flow Control Corporation, reserves the right, without notice, to alter or improve the designs or specifications of the products described herein.